

Logistic Pallet

PG1090

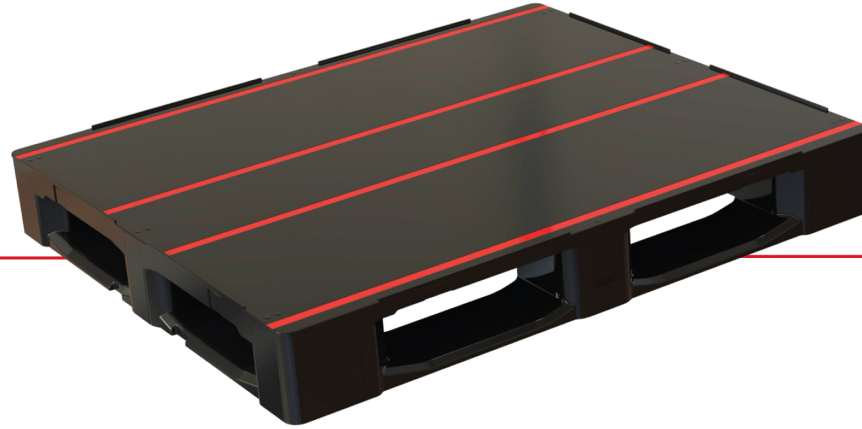

PG1090

Plasgad[®]
SMART PACKAGING
YOUR WAY



- Can be tailored to specific needs with a wide range of customization options
- Designed for heavy loads
- Racking capabilities
- Low self weight
- Environmentally friendly - 100% recyclable
- Easy washing and cleaning
- Optimized to fit conveyors and automated systems
- Rubber anti-slip gems / strips
- 3 optional safety rims
- Optional GPS/IOT tracking device to provide real time data
- UV Resistant

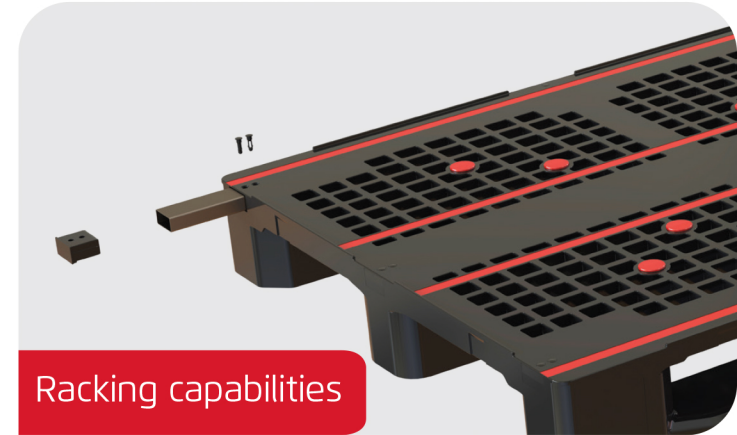

Racking capabilities

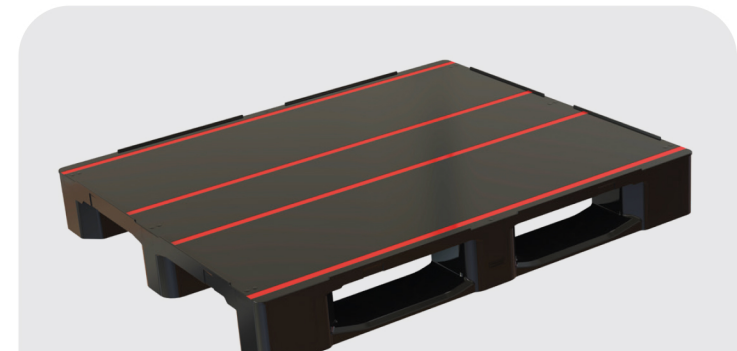

3 Runners closed deck

Specifications

DIMENSIONS

Dimensions (L/W/H) 47.2 / 39.4 / 6.2 in 1,200 / 1,000 / 157 mm

LOGISTICS

	3 Runners	3 Runners + HM	3 Runners + 3M	5 Runners	5 Runners + HM	5 Runners + 3M
Weight	33.5 lb	43.3 lb	44.1 lb	35.9 lb	45.7 lb	46.6 lb
	15.2 kg	19.6 kg	20 kg	16.3 kg	20.7 kg	21.1 kg
Weight CD	35.2 lb	45 lb	45.9 lb	37.6 lb	47.4 lb	48.3 lb
	16 kg	20.4 kg	20.8 kg	17.1 kg	21.5 kg	21.9 kg
Maximum load Dynamic	4,409 lb	4,409 lb	4,409 lb	4,409 lb	4,409 lb	4,409 lb
	2,000 kg	2,000 kg	2,000 kg	2,000 kg	2,000 kg	2,000 kg
Maximum load Static	11,023 lb	11,023 lb	11,023 lb	13,227 lb	13,227 lb	13,227 lb
	5,000 kg	5,000 kg	5,000 kg	6,000 kg	6,000 kg	6,000 kg
Racking (with skids)	1,322.7 lb	2,204 lb	3,307 lb	1,543 lb	2,204 lb	3,307 lb
	600 kg	1,000 kg	1,500 kg	700 kg	1,000 kg	1,500 kg
Pallets per stack	16	16	16	16	16	16

TRANSPORT

40' HC 336

53' Truck 480

* Load capacities are based on evenly distributed loads and can vary according to the type of load.

Technical Drawing (mm)

3 Runners

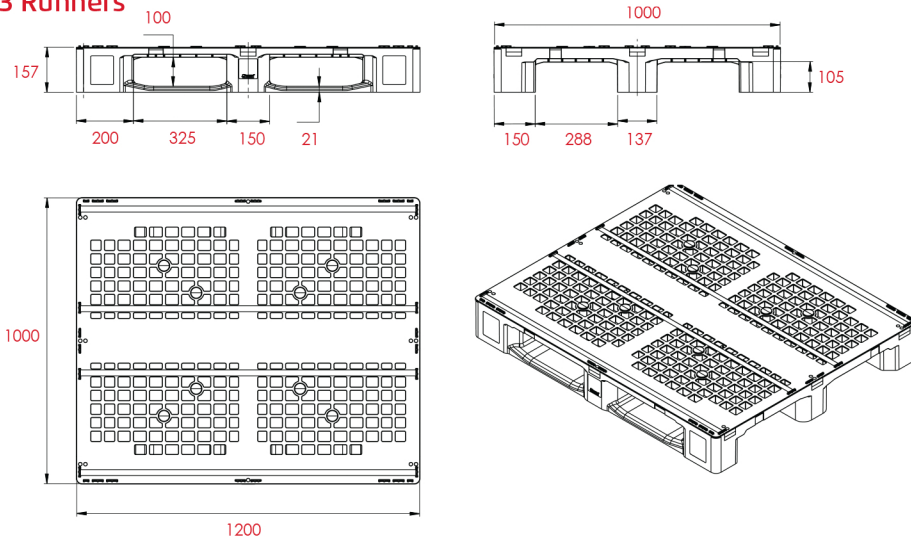

5 Runners

