

PG1090+ Logistic Pallet

Features and advantages

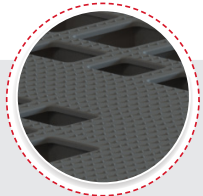

Rough surface for better grip

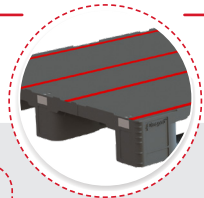

Closed deck (optional)

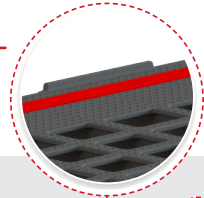

Optional safety rim

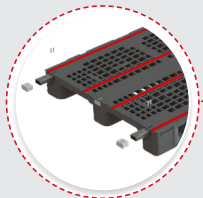
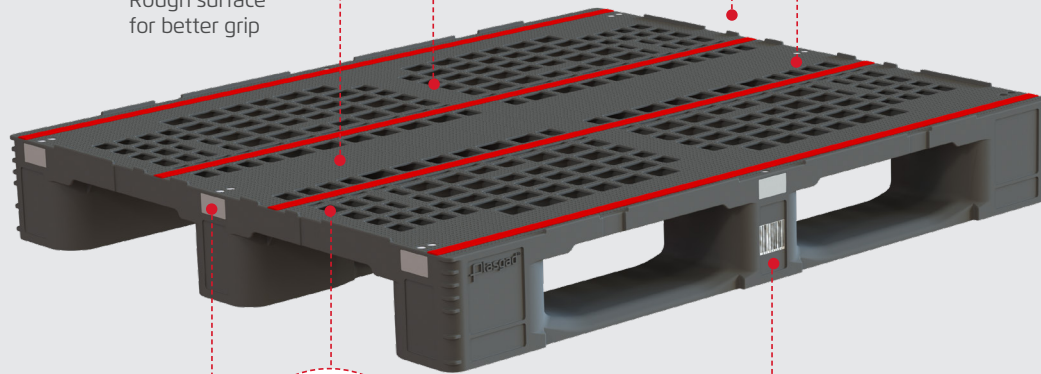

Optional metal reinforcements for improved racking capabilities

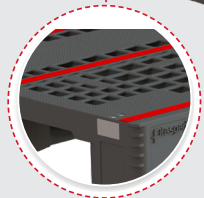

Anti-slip deck strips to protect goods



Protected area for identification sticker/IML in 6 different designated places

Anti-slip add-ons for better grip

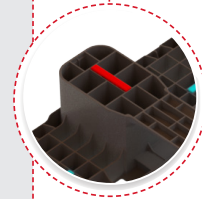
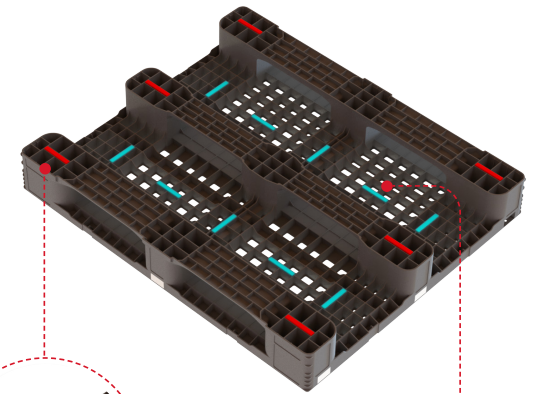

Anti-slip pallet legs, ideal for mobile racking systems



Grip-enhancing rubber to prevent forklift skidding

More advantages

- Can be tailored to specific needs
- Designed for heavy loads with racking capabilities
- Optimized for conveyor belts and automated systems
- Low self-weight
- Environmentally friendly - 100% recyclable
- Easy washing and cleaning
- Optional GPS/IOT tracking device to provide real time data

Specifications

DIMENSIONS						
External Dimensions (L / W / H)	1,200 / 1,000 / 157 mm		47.2 / 39.4 / 6.2 in			
LOGISTICS						
	3 skids		3 skids + HM		3 skids + 3M	
Weight	15.2 kg	33.5 lb	19.6 kg	43.21 lb	20 kg	44.1 lb
Weight CD	16 kg	35.3 lb	20.4 kg	44.5 lb	20.8 kg	45.8 lb
Maximum load Dynamic	2,000 kg	4,408 lb	2,000 kg	4,408 lb	2,000 kg	4,408 lb
Maximum load Static	6,000 kg	13,227 lb	6,000 kg	13,227 lb	6,000 kg	13,227 lb
Racking	600 kg	1,322.7 lb	1,400 kg	3,086 lb	1,500 kg	3,307 lb
Pallets per stack / Reverse Stack	16 / 22		16 / 22		16 / 22	
TRANSPORTATION						
Units per 40HC / Reverse Stack	336 / 380					
Units per 53' Truck	510					
MATERIAL						
Material	PP/HDPE recycled or virgin					
Color	Recycled – black/grey Virgin – any color					

Technical Drawing

